











IM-17100

Extra Heavy Duty Window Wiper

High voltage systems ideal for average to high speed vessels

-  Pantograph and pendulum
-  Arms with blades up to 78ins. (2000mm) available for average speed vessels
-  Arms with blades up to 59ins. (1500mm) available for high speed vessels
-  Fixed arc or variable arc models
-  Ranges from 48 to 230 volt AC or DC
-  Two speeds
-  Self parking facility
-  Insulated earth return and EMC filter are standard
-  Operated by a multi-speed / function control system





IM-17100

Extra Heavy Duty Window Wiper

High voltage systems ideal for average to high speed vessels

Specifications

Standard Details	2 Speed; Self Parking; Insulated Earth Return: 12v, 24v, 72v, 96v, 110v DC, 110v - 220v AC
Angles of Arc - Fixed	
Pantograph Units	45° to 90° (in 5° increments only)
Pendulum Units	45° to 115° (in 5° increments only)
Spindle Centres	Between Drive Liner & Idler = 60mm Pantograph Units only
Drive Liner	M26 - Brass Liner / 16mm SS Spindle Pantograph & Pendulum Units
Liner Overall Length	Bulkhead Thickness + 55mm
Idler Liner	M26 - Brass Liner / 16mm SS Spindle Pantograph Units only
Bracket	L - Left Hand Bracket; R - Right Hand Bracket;
Unit Weight	Allowing for the maximum arm and blade lengths; 9.2Kgs (20.0 lbs)

Illustration shows options of parking

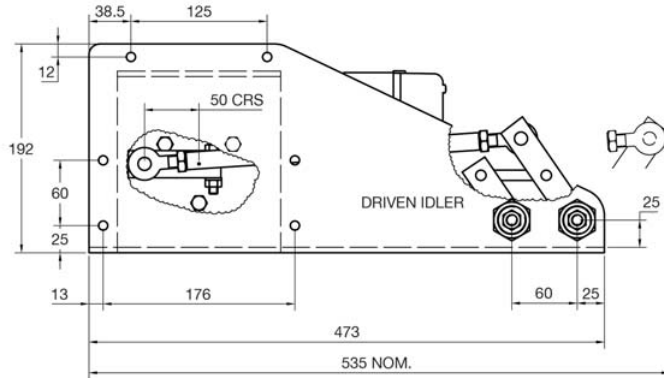
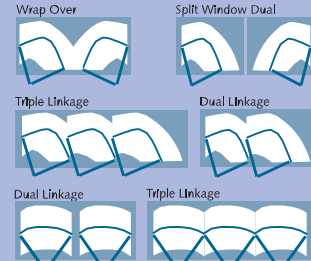
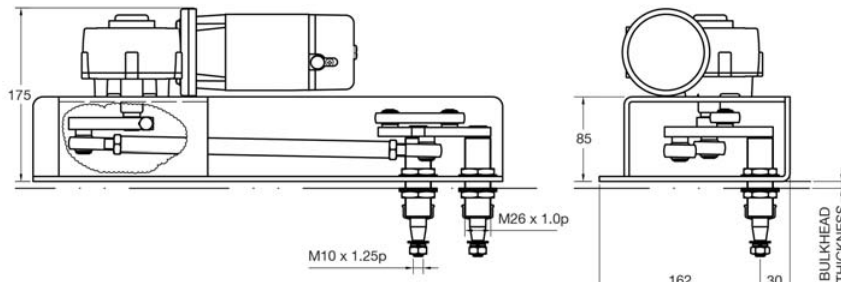

Illustration shows options of parking



When very wide or multiple windows are to be swept we offer a comprehensive range of swept area solutions utilising the 100Nm drive unit operating either two or three arms and blades off one motor.
This offers customers the benefit of simpler installations as well as cost saving.

Wiper Arms and Blades

■ Pantograph Arms

P84	Heavy Duty
Lengths	24" to 98" (610mm to 2500mm) nom
Drive Head	16mm
Blade Clip	14mm & 20mm

■ Pendulum Arms

F80	Heavy Duty
Lengths	24" to 72" (610mm to 1830mm) nom
Drive Head	16mm
Blade Clip	14mm
F81	Heavy Duty
Lengths	24" to 72" (610mm to 1830mm) nom
Drive Head	16mm
Blade Clip	20mm

■ Blades

B140	Curved Blade
Lengths	12" to 28" (310mm to 710mm) nom
For use with arm types:	
Pendulum	F80 Pantograph P84
B140	Curved Blade
Lengths	32" (810mm), 36" (915mm), 39" (1000mm)
For use with arm types:	
Pendulum	F81 Pantograph P84

In-Mar Solutions, LLC

Ph: (225) 644-7063
Fax: (225) 644-7046

Email: info@inmarsystems.com
Web: www.inmarsystems.com